

**TECHNICAL MANUAL**

**OPERATOR'S, ORGANIZATIONAL, DIRECT SUPPORT  
AND GENERAL SUPPORT MAINTENANCE  
MANUAL INCLUDING REPAIR PARTS LIST  
FOR**

**TANK, PRESSURE  
MODEL ASME-A-3  
(PAASCHE AIR BRUSH CO.)  
(NSN 4940-00-251-6478)**

**HEADQUARTERS, DEPARTMENT OF THE ARMY  
MAY 1980**

TECHNICAL MANUAL

No. 9-4940-411-14&amp;P



HEADQUARTERS  
DEPARTMENT OF THE ARMY  
WASHINGTON DC, 9 May 1980

**OPERATOR'S ORGANIZATIONAL, DIRECT SUPPORT  
AND GENERAL SUPPORT MAINTENANCE  
MANUAL INCLUDING REPAIR PARTS LIST  
FOR  
TANK, PRESSURE  
MODEL ASME-A3  
(PAASCHE AIR BRUSH CO.)  
(NSN 4940-00-251-6478)**

**REPORTING OF ERRORS**

You can improve this manual by recommending improvements using, DA Form 2028 (Recommended Changes to Publications and Blank Forms) or DA Form 2028-2 located in the back of this manual. Mail your form direct to Commander, US Army Armament Materiel Readiness Command, ATTN: DRSAR-MAS, Rock Island, IL 61299. A reply will be furnished direct to you.

**NOTE**

This manual is published for the purpose of identifying an authorized commercial manual for the use of the personnel to whom the tank is issued.

Manufactured by: Paasche Airbrush Company  
1909 W. Diversey Parkway  
Chicago, IL 60614

Procured under Contract No. DAAA09-75-M-8505

This technical manual is an authentication of the manufacturers' commercial literature and does not conform with the format and content specified in AR 310-3, Military Publications. This technical manual does, however, contain available information that is essential to the operation and maintenance of the equipment.

**INSTRUCTIONS FOR REQUISITIONING PARTS  
NOT IDENTIFIED BY NSN**

When requisitioning parts not identified by National Stock Number, it is mandatory that the following information be furnished the supply officer.

- 1- Manufacturer's Federal Supply Code Number -
- 2- Manufacturer's Part Number exactly as listed herein.
- 3- Nomenclature exactly as listed herein, including dimensions, if necessary.
- 4- Manufacturer's Model Number-
- 5- Manufacturer's Serial Number (End Item)
- 6- Any other information such as Type, Frame Number, and Electrical Characteristics, if applicable.
- 7- If DD Form 1348 is used, fill in all blocks except 4, 5, 6, and Remarks field in accordance with AR 725-50.

Complete Form as Follows:

- (a) In blocks 4, 5, 6, list manufacturer's Federal Supply Code Number followed by a colon and manufacturer's Part Number for the repair part.
- (b) Complete Remarks field as follows:  
Noun: (nomenclature of repair part)

For: NSN:

Manufacturer:

Model:

Serial:

Any other pertinent information such as frame number, type, dimensions, etc.

Airmotor Agitators

OPERATING INSTRUCTIONS

#1- AIRMOTOR AGITATOR for ASME-AS  
GALLON and LARGER PRESSURE  
FLUID TANKS

#5 SMALL SIZE AIRMOTOR AGITATOR  
for ASME-A3 GALLON PRESSURE  
FLUID TANKS

**#3 & #4 AIRMOTOR AGITATOR for CLAMPING TO OPEN TOP CONTAINERS**

Ball - Bearing Airmotor Agitators operate for long periods of time with very little attention. This explosion-proof unit will keep most types of finishing materials mixed to uniform consistency. The Agitator Propellers create a continuous circulating and mixing action. Adjustable speed control provides quick action for

starting agitation, after which airmotor should be adjusted to lowest practical speed to conserve air and prevent over agitation or mixing. "V" type packing will last indefinitely when oiled with best grade lubricant every 30 days.

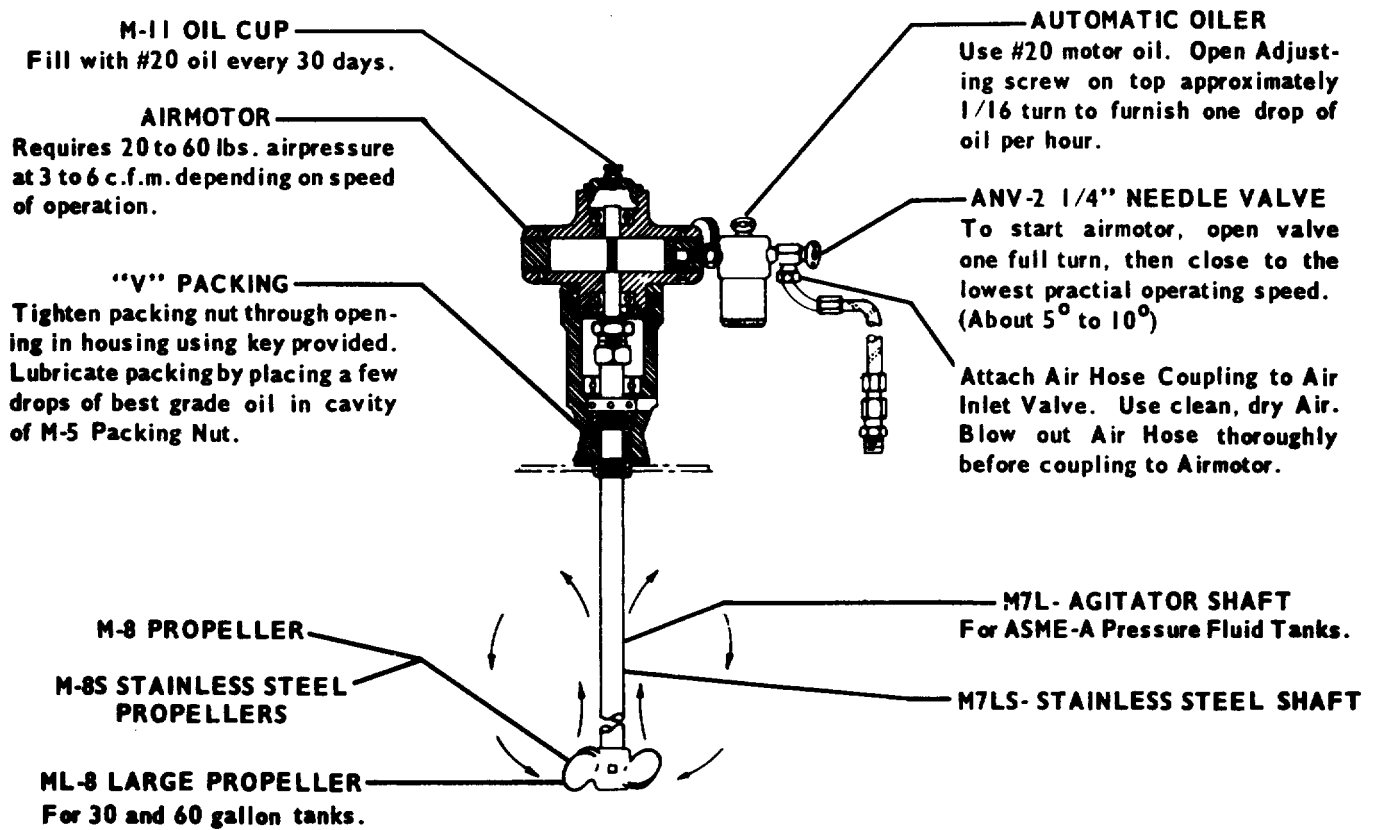

**CAUTION:**

When using Airmotor Agitator DO NOT FILL Pressure Tank more than Three Quarters Full. When Mounting Airmotor Agitator Unit to M-1 Housing - Adjust all set screws equally to prevent misalignment of Agitator Shaft.

## #5 AIRMOTOR AGITATOR FOR ASME-A3 PRESSURE FEED MATERIAL TANKS

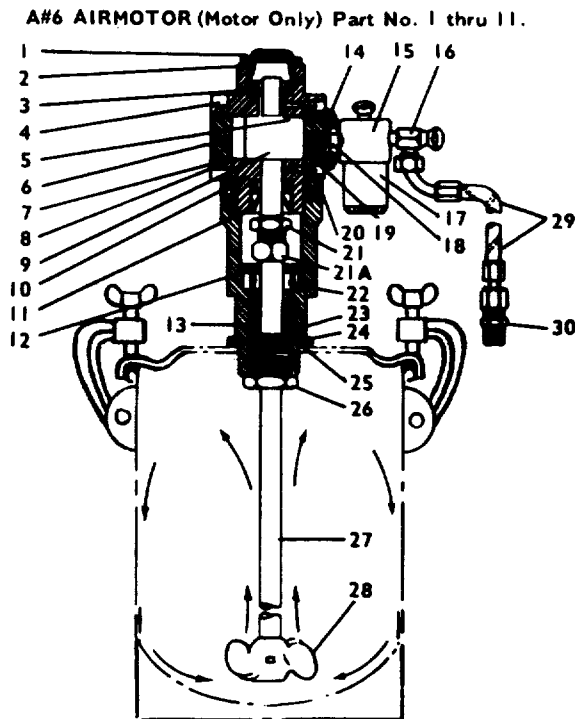

**#5 AIRMOTOR AGITATOR for use with ASME-A3 Gallon Tank,  
Complete with M-48-12 Shaft and M-50 Propeller.**

AIRMOTOR AGITATOR Complete for:  
 ASME-A3 Gallon Tank #S -12-7/8" Airmotor Agitator (1 Propeller)  
 ASME-A3 Gallon Tank #5S -12-7/8" Airmotor Agitator (1 Propeller)  
 Letter "S" INDICATES STAINLESS STEEL PARTS

### #5 AIRMOTOR AGITATOR PART NO. & DESCRIPTION

- |   |   |
|---|---|
| 1. M-55 End Cap   | 21. M-47 Locknut  |
| 2. M-56 End Cap Gasket  | 21A. M-46 Coupling Chuck  |
| 3. M-57 Ball Bearing (2 Required)                             | 22. M-43 Ball Bearing   |
| 4. M-84 Screw (Philip Head-10 Required)                       | 23. M-40 Packing Gland  |
| 5. M-58 Dead End Plate  | 24. M-41 Packing Spring   |
| 6. M-60 Housing   | 25. M-25 Gasket   |
| 7. M-59 Body Gasket   | 26. M-53 Packing Nut  |
| 8. M-61 Rotor Vanes (4 Required)                              | 27. #5 AIRMOTOR AGITATOR SHAFTS for AS1E-A3<br>GAL. M-48-12 -7/8" Shaft for ASME-A3 Gallon<br>Tanks M.-48S-12 -7/8" Shaft for ASME-A3 Gallon<br>Tanks       |
| 9. M-62 Rotor Assembly  | 28. #5 AIRMOTOR AGITATOR PROPELLERS<br>M-50 Propeller for ASME-A3 Gallon Tanks<br>(Required) M-50S St.St. Propeller for ASME-A3<br>Gallon Tanks(1 Required) |
| 10. M-63 Drive End Plate                                      | ACCESSORIES with AGITATOR   |
| 11. M-44 Seal   | 29. HL-3/16"-10" Air Hose with Coupling<br>HLC-3/16"-1/4" Coupling<br>HLC-3/16"-1/4"-90 Coupling  |
| 12. M-38 Felt Washer  | 30. HF-33 Coupler   |
| 13. M-39 Packing (1/8" Twist String Type approx. 10"<br>long) | Letter "S" INDICATES STAINLESS STEEL PARTS  |
| 14. M-49 Muffler Assembly                                     |   |
| 15. M-10 Oiler  |   |
| 16. ANV-2 -1/4" Needle Valve                                  |   |
| 17. U-2210 Oil Cap  |   |
| 18. HF-233 Coupler  |   |
| 19. M-54 Housing  |   |
| 20. M-44 Set Screw (2 Required)                               |   |

AA#3. AA#4 and PU-385 Clamp available for use with  
 5 Gallon Pail or 50 Gallon Drums.

1. CLEAN OUT TANK and blow out all hose before using. Always use hose of ample size.
2. MATERIAL TO BE USED must be thoroughly mixed and strained through a fine mesh strainer or cheesecloth before or while pouring into tank. Follow material manufacturers instructions regarding proper type and amount of thinner to be used.
3. When using the Airmotor Agitator do not fill tank over the required amount, 3/4 Full .This is to prevent paint from entering the Agitator Bearings.
4. PLACE COVER ON TANK. Turn each clamp down until it touches the cover. Proceed around the cover, turning each clamp one full turn until all are tight. This method insures longer gasket life and uniform sealing.
5. FOLLOW HOOK-UP INSTRUCTIONS AT RIGHT.
6. OPEN AIR LINE VALVE on Air Regulator and Moisture Condensor Unit to allow air pressure to enter tank.
7. ADJUST AIR PRESSURE for material by turning the adjusting handle on the tank regulator until the gauge indicates approximately 5 lbs. When it is necessary to decrease pressure in the tank, the excess pressure must first be released by opening the release valve.
  - a. **CAUTION: Release valve should be opened before removing filler plug or cover.**
8. PROPER FLUID PRESSURE will vary from 2 lbs. upward, depending upon the consistency of the material and the height to which fluid must be raised.
9. FLUID PRESSURE should be adjusted to give a uniform flow. Use lowest pressure that gives satisfactory results.
10. TO CLEAN HOOK-UP, Remove all pressure from the tank by opening the release valve. Then force material back into the tank by loosening the air cap of the gun, holding a wad of cloth over the air cap and pulling the trigger. Air thus diverted into the fluid lines forces material back into the container. Remove material from the tank and replace with clean solvent. Apply pressure again to the tank and spray solvent through the gun to flush out the fluid passages and hose. Wipe off equipment with a solvent soaked rag.
11. NEVER ALLOW SAFETY VALVE TO BECOME COVERED WITH PAINT.

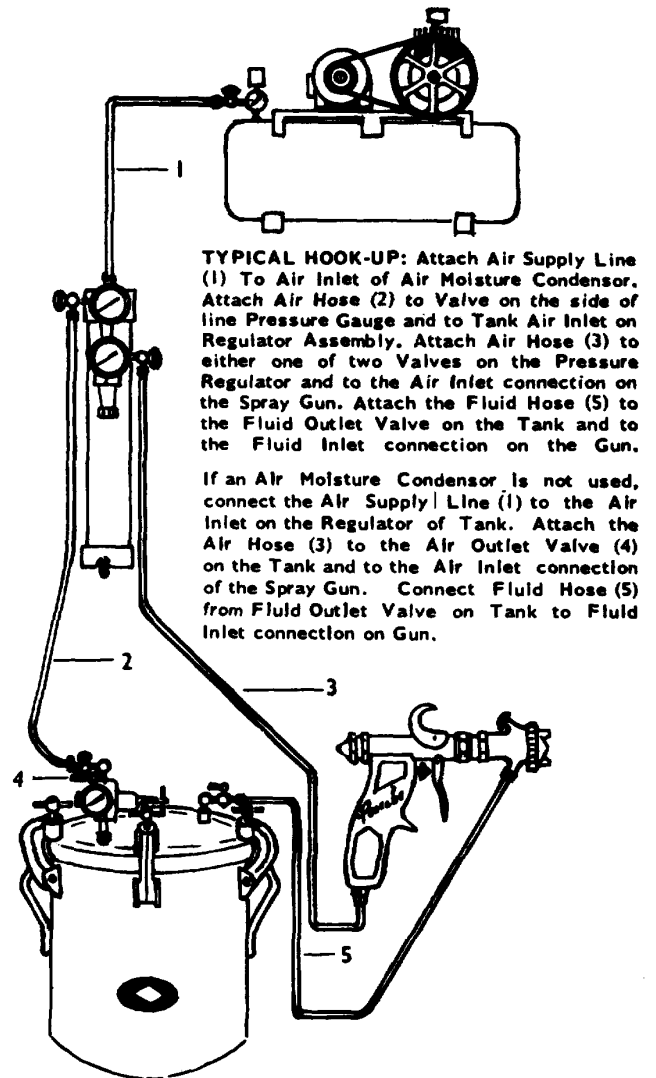

#### CARE AND CLEANING

1. Tank should be kept in upright position to keep liquids and materials away from inside part of Cover, Air Passales Must Stay Clean.
2. PU 566 Splash Cap on Regulator Air Outlet inside Tank Cover should be inspected periodically to make sure Air Ports are open to admit Airpressure entering Tank.
3. U8II Air Inlet Strainer in Tank should be Cleaned periodically to remove any skins or heavy particles which might clog the openings. The same applies to the Spray Gun and Tank Regulator.

#### MATERIAL:

Fluid material should be mixed to consistency recommended by manufacturer and should always be strained through a lint free cloth or metal screen before using.

## ASME-A3, 5, 10, 20, 30 AND 60 GALLON TANK PARTS LIST

REGULATOR ON ALL ASME-A TANKS R4LT-1-1/4" WITH PARTS ARE LISTED ON PAGE 3.

### ASME-A3 GALLON TANK PARTS

No.	PART	DESCRIPTION
1.	PU-685	Shell
2.	PU-686	Cover
3.	PU-719	Buna "N" Gasket
4.	70-5330	3/8" x 3/8" Valve
5.	HF-3/8"-90	Elbow
6.	R4LT-1-1/4."	Regulator
7.	PU-690	3/4" sq. Hd. Galv., Plug
8.	PU-687	Wing Screw (4 Required)
9.	PU-688	Clamp (4 Required)
10.	PU-689	Pin (4 Required)
11.	PU-3/8"-11"	Fluid Pipe
12.	PU-691	1" Socket Hd. Galv. Plug

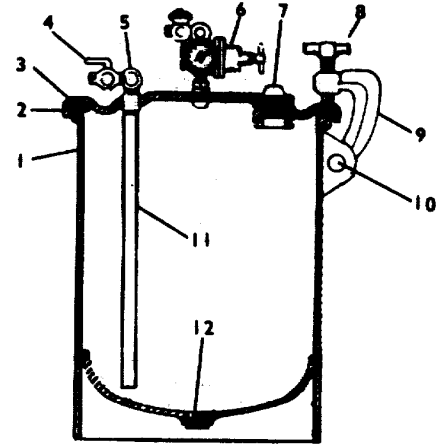

**ASME-A3 GALLON TANK**

### ASME-A5. 10, 20, 30 AND 60 GALLON TANKS PARTS

No.	PART	DESCRIPTION
1.	PU-92 Shell (For 5 Gal. Tank)	
	PU-694 Shell (For 10 Gal. Tank)	
	PU-696 Shell (For 20 Gal. Tank)	
	PU-701 Shell (For 30 Gal. Tank)	
	PU-702 Shell (For 60 Gal. Tank)	
2.	PU-693 Cover (For 5, 10 and 20 Gal. Tank)	
	PU-703 Cover (For 30 and 60 Gal. Tank)	
3.	PU-720 Buna "N" Gasket (For 5, 10 and 20 Gal. Tank)	
	PU-731 Buna "N" Gasket (For 30 and 60 Gal. Tank)	
4.	70-5330	3/8" x 3/8" Valve
5.	HF-3/8"-90	Elbow
6.	R4LT-1-1/4"	Regulator
7.	PU-690	3/4" sq. Nd. Galv. Plug
13.	PU-698 Filler Plug (For 5, 10 and 20 Gal. Tank)	
	PU-704 Filler Cap (For 30 and 60 Gal. Tank)	
14.	PU-728 Thiokol Filler Plug Gasket (For 5, 10 and 20 Gal. Tank)	
	PU-706 Filler Cap Gasket (For 30 and 60 Gal. Tank)	
15.	PU-699 Wing Screw (6 Required for 5, 10 and 20 Gal. Tank)	
	PU-714 Wing Screw (12 Required for 30 and 60 Gal. Tank)	
16.	PU-695 Clamp (6 Required for 5 and 10 Gal. Tank)	
	PU-697 Clamp (6 Required for 20 Gal. Tank)	
	PU-715 Clamp (12 Required for 30 and 60 Gal. Tank)	
17.	PU-700 Pin (6 Required for 5, 10 and 20 Gal. Tank)	
	PU-716 Pin (12 Required for 30 and 60 Gal. Tank)	
18.	PU-3/8"-12-1/2" Fluid Pipe (For 5 Gal. Tank)	
	PU-3/8"-18-1/2" Fluid Pipe (For 10 Gal. Tank)	
	PU-3/8"-36" Fluid Pipe (For 20 Gal. Tank)	
	PU-1/2"-21-1/2" Fluid Pipe (For 30 Gal. Tank)	
	PU-1/2"-36" Fluid Pipe (For 60 Gal. Tank)	
12.	PU-691	1" Socket Nd. Galv. Plug (For 5, 10 and 20 Gal. Tank)
	PU-671	Bottom Outlet Plug (For 30 Gal. Tank)
	PU-672	Bottom Outlet Plug (For 60 Gal. Tank)

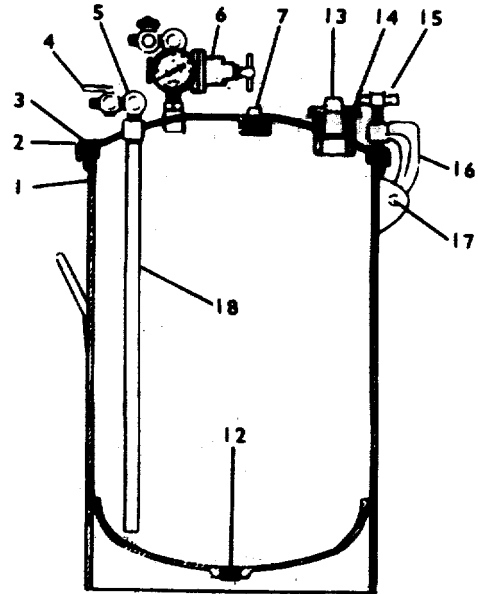

**ASME-A5, 10, 20, 30 AND 60 GALLON TANKS**

**For Airmotor Agitator Parts see the parts list enclosed with Agitator.**

ASME-A3, 5, 10, 20, 30 AND 60 GALLON TANKS AIR REGULATOR PARTS

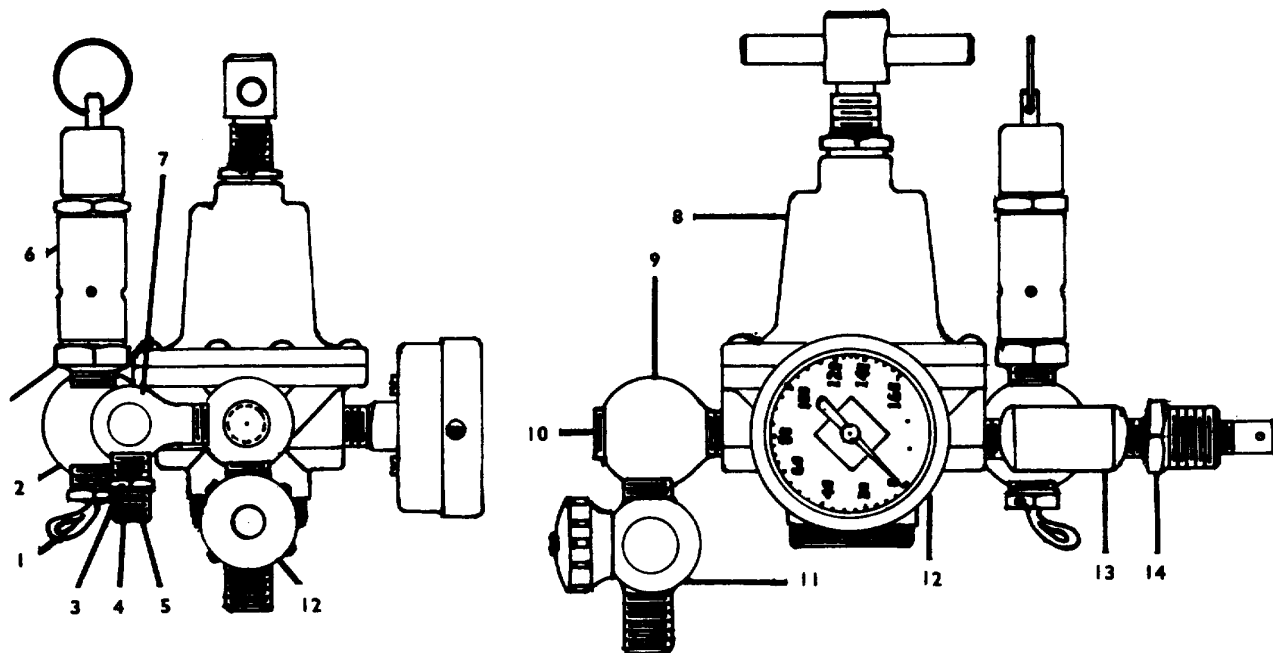

\*\* R4LT-1-1/4" REGULATOR

\*\* R4LT-1-1/4" REGULATOR WITH PARTS LISTED

No. PART	DESCRIPTION	No. PART	DESCRIPTION
1.	HRV-1/4" Release Valve	8.	R-65-1/4" Regulator
2.	HF-564L 3 Way Tee	9.	HF-560L 4 Way Tee
3.	HF-33S Coupler W/Strainer	10.	1/4" Allen Pipe Plug
4.	U-811 Air Inlet Strainer	11.	HF-1 /4" Valve
5.	DH-74 Retaining Ring	12.	GB-2"-60# or GB-2"9-160# Gauge
6.	PU-725 ASME Pop Valve	13.	HF-342-1/4" 3 Way Tee
7.	HF-1/4"-90 Elbow	14.	HF-34AS Splash Coupler

\*\* Specify 1 or 2 Outlets.

**CAUTION**

When filling Tank with Inflammable materials, explosive vapors will ignite from Static or Electric Spark due to contact of metal can with top of Tank. When using this or any other type material .... Do Not forget the Fire and Safety Regulations. Do not use strong Alkali Solutions an they will destroy the Galvanized Lining of the Tank. Certain Material my be allowed to stand In Tank for days, providing connections remain tight and no Air gets Into Fluid Line to cause material to harden. Make sure proper room Ventilation Is provided during operation and use of any type material. Approved Ventilating Equipment should be used.

Air pressures are required, heavy materiel requires higher Pressure. The Speed of Application depends upon the Size of Spray Gun. Air pressures and C.F.M. capacity of Multiplehead.

- Do not use excessive Air pressure on Fluid in Tank as this will force the Paint out faster than the Spray Gun can Atomize it, causing rough Finish. The Tank Pressure should range from two pounds and higher, depending upon the consistency of material, the length of Fluid Hose and height the material must be raised above the level of the Tank. Generally, the Pressure should be increased 1 lb. per ft. of elevation and regulated so the material flows slowly from the Spray Gun Fluid Tip when Atomizing Pressure is shut off and Trigger Is drawn back.
- After Fluid Regulator Is properly Regulated,. adjust Atomizing Pressure which gives satisfactory results so fumes and mist will be held to a minimum and waste of material eliminated. Light materials require 10 to 30 lbs. Pressure for Atomization. medium consistency Finishing materials 30 to 50 lbs. and heavy material 50 to 100 lbs.

**AIR SUPPLY**

- An adequate Supply of Compressed Air is essential for proper Atomization of all types of Coating and Finishing materials. For light consistency Fluid, Low



**ASME-A3, 5, 10, 20, 30 AND 60 GALLON TANKS ACCESSORIES**

For TANK, AIR REGULATOR and BOTTOM OUTLET ASSEMBLIES ORDER ASME-A-B3, ASME-A-B5, ASME-A-B10, ASME-A-B20, ASME-A-B30 or ASME-A-B60 GALLON TANKS.

**BOTTOM OUTLET ASSEMBLIES FOR ASME-A3, 5, 10 and 20 GALLON TANKS**

**No. PART & DESCRIPTION**

- 1. 1" x 90 Str. Elbow Galv.
- 2. 1" x 5 1/2" Nipple (For 3 Gal. Tank)
- 1" x 8" Nipple (For 5, 10 and 20 Gal. Tank)
- 3. 1" Gate Valve
- 4. 1" Close Nipple
- 5. PU-599 Leg (3 Required)

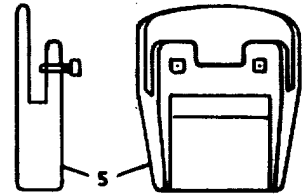
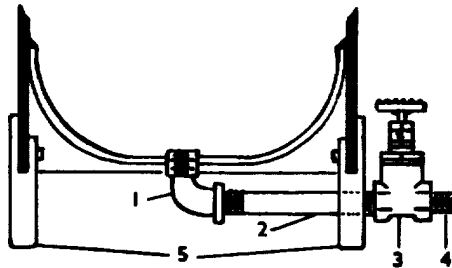

PU-599 LEG ( 3 Required )

**BOTTOM OUTLET ASSEMBLY FOR ASME-A 3 , 5 , 10 AND 20 GALLON TANKS.**

**BOTTOM OUTLET ASSEMBLIES FOR ASME-A30 and 60 GALLON TANKS**

**No. PART & DESCRIPTION**

- 1. 1 1/2" Close Nipple
- 2. 1" x 1 1/2" Galv. Reducing Elbow
- 3. 1" x 12" Nipple
- 4. 1" Gate Valve
- 5. 1" Close Nipple

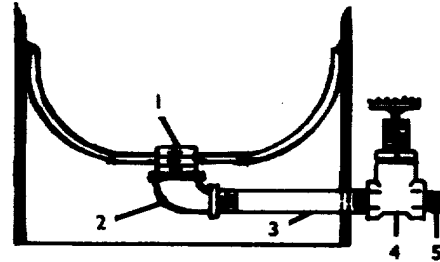

**BOTTOM OUTLET FOR ASME-A 30 AND 60 GALLON TANKS.**

**REFILL CONTAINERS FOR ASME-A TANKS**

Refill Containers and Covers: Galvanized or Stainless Steel containers are easily removed or re-inserted in ASME-A Tanks for speed in making color changes. Convenient for material mixing, handling and storage.

R- GALVANIZED STEEL  
RS- STAINLESS STEEL

Part No.	DESCRIPTOIN & TANK
R-2 or RS-2	Refill Container (For ASME-A3)
R-8 or RS-8	Refill Container (For ASME-A5)
R-9 or RS-9	Refill Container (For ASME-A10)
R-10 or RS-10	Refill Container (For ASME-A20)
R-11 or RS-11	Refill Container (For ASME-A30)
R-12 or RS-12	Refill Container (For ASME-A60)

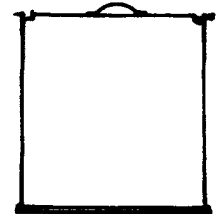

R- or RS- REFILL CONTAINER

**WHEEL BASE**

Wheel bases (Truck) for easy moving of pressure tanks or refill containers. Steel base has 3 or 4 ball bearing swivel casters. Made for those tanks listed :

PART NO.	DESCRIPTION & TANK
3WT Truck-5, 10 or 20 Gallon Tanks (3 Wheels)	
4WT Truck-30 or 60 Gallon Tanks (4 Wheels)	

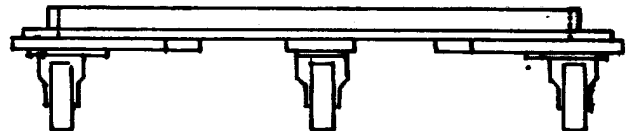

3WT TRUCK

PU-72 heavy-duty paint strainer (with a 40 mesh screen) straddles top of tank.

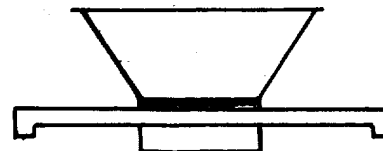

PU-72 PAINT STRAINER

By Order of the Secretary of the Army:

Official:

J. C. PENNINGTON  
Major General, United States Army  
The Adjutant General

E. C. MEYER  
General, United States Army  
Chief of Staff

\*U.S GOVERNMENT PRINTING OFFICE: 1993 -342-421/62379

RECOMMENDED CHANGES TO EQUIPMENT TECHNICAL PUBLICATIONS



*THEN...JOT DOWN THE  
DOPE ABOUT IT ON THIS FORM.  
CAREFULLY TEAR IT OUT, FOLD IT  
AND DROP IT IN THE MAIL.*

**SOMETHING WRONG WITH PUBLICATION**

FROM: (PRINT YOUR UNIT'S COMPLETE ADDRESS)

DATE SENT

PUBLICATION NUMBER

PUBLICATION DATE

PUBLICATION TITLE

BE EXACT PIN-POINT WHERE IT IS

PAGE NO.	PARA-GRAPH	FIGURE NO.	TABLE NO.

IN THIS SPACE, TELL WHAT IS WRONG AND WHAT SHOULD BE DONE ABOUT IT.

PRINTED NAME, GRADE OR TITLE AND TELEPHONE NUMBER

SIGN HERE

## The Metric System and Equivalents

### **Linear Measure**

1 centimeter = 10 millimeters = .39 inch  
 1 decimeter = 10 centimeters = 3.94 inches  
 1 meter = 10 decimeters = 39.37 inches  
 1 dekameter = 10 meters = 32.8 feet  
 1 hectometer = 10 dekameters = 328.08 feet  
 1 kilometer = 10 hectometers = 3,280.8 feet

### **Weights**

1 centigram = 10 milligrams = .15 grain  
 1 decigram = 10 centigrams = 1.54 grains  
 1 gram = 10 decigram = .035 ounce  
 1 decagram = 10 grams = .35 ounce  
 acres  
 1 hectogram = 10 decagrams = 3.52 ounces  
 1 kilogram = 10 hectograms = 2.2 pounds  
 1 quintal = 100 kilograms = 220.46 pounds  
 1 metric ton = 10 quintals = 1.1 short tons

### **Liquid Measure**

1 centiliter = 10 milliliters = .34 fl. ounce  
 1 deciliter = 10 centiliters = 3.38 fl. ounces  
 1 liter = 10 deciliters = 33.81 fl. ounces  
 1 dekaliter = 10 liters = 2.64 gallons  
 1 hectoliter = 10 dekaliters = 26.42 gallons  
 1 kiloliter = 10 hectoliters = 264.18 gallons

### **Square Measure**

1 sq. centimeter = 100 sq. millimeters = .155 sq. inch  
 1 sq. decimeter = 100 sq. centimeters = 15.5 sq. inches  
 1 sq. meter (centare) = 100 sq. decimeters = 10.76 sq. feet  
 1 sq. dekameter (are) = 100 sq. meters = 1,076.4 sq. feet  
 1 sq. hectometer (hectare) = 100 sq. dekameters = 2.47  
 1 sq. kilometer = 100 sq. hectometers = .386 sq. mile

### **Cubic Measure**

1 cu. centimeter = 1000 cu. millimeters = .06 cu. inch  
 1 cu. decimeter = 1000 cu. centimeters = 61.02 cu. inches  
 1 cu. meter = 1000 cu. decimeters = 35.31 cu. feet

### **Approximate Conversion Factors**

<b>To change</b>	<b>To</b>	<b>Multiply by</b>	<b>To change</b>	<b>To</b>	<b>Multiply by</b>
inches	centimeters	2.540	ounce-inches	Newton-meters	.007062
feet	meters	.305	centimeters	inches	.394
yards	meters	.914	meters	feet	3.280
miles	kilometers	1.609	meters	yards	1.094
square inches	square centimeters	6.451	kilometers	miles	.621
square feet	square meters	.093	square centimeters	square inches	.155
square yards	square meters	.836	square meters	square feet	10.764
square miles	square kilometers	2.590	square meters	square yards	1.196
acres	square hectometers	.405	square kilometers	square miles	.386
cubic feet	cubic meters	.028	square hectometers	acres	2.471
cubic yards	cubic meters	.765	cubic meters	cubic feet	35.315
fluid ounces	milliliters	29,573	cubic meters	cubic yards	1.308
pints	liters	.473	milliliters	fluid ounces	.034
quarts	liters	.946	liters	pints	2.113
gallons	liters	3.785	liters	quarts	1.057
ounces	grams	28.349	liters	gallons	.264
pounds	kilograms	.454	grams	ounces	.035
short tons	metric tons	.907	kilograms	pounds	2.205
pound-feet	Newton-meters	1.356	metric tons	short tons	1.102
pound-inches	Newton-meters	.11296			

### **Temperature (Exact)**

°F	Fahrenheit temperature	5/9 (after subtracting 32)	Celsius temperature	°C
----	---------------------------	-------------------------------	------------------------	----

**PIN: 045352-000**